

RAILROAD SCAFFOLD SL-RRP10

The Railroad Wrap-Around Scaffold is designed to provide access to all sides of a railroad girder bridge.

2 each 28 inch wide x desired length aluminum stage (not included in package below). Guardrails, Guardrail Post, and Connectors, provided on page 26. Determine quantity and add to package below.

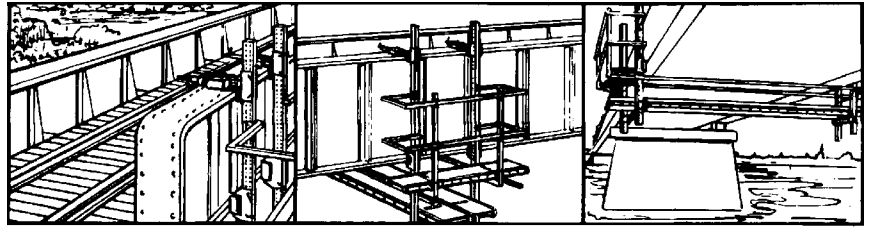

SL-RRP10 RAIL ROAD WRAP AROUND SCAFFOLD		
MODEL	DESCRIPTION	QTY
SL-10UA	Adjustable Upper Head Assembly 16 - 22" exp.	4
SL-7012	12' Vertical Perforated Stem	4
SL-10LAS	Lower Wheel Assembly	8
SL-24SBB	24" Stage Bracket w/Lock Clips	4
SL-15AB059C	1.5" sq. x 59" Channel Brace	2
SL-15AB059T	1.5" sq. x 59" Tubing Brace	2
SL-15GRPA	1.5" sq. x 48" Aluminum Guardrail Post	4
SL-GR0800	1.5" sq. x 80" Aluminum Guardrail	8
SL-GR0160B	1.5" sq. x 61" Aluminum Guardrail	8
SL-24ERL	1.5" sq. x 24" Aluminum Endrails	8
SL-64D	Side Mounted Ladder Clamp	2
SL-D2407	2' x 7" Aluminum Stage	2
SL-15WB	Diagonal Brace	4
SL-15TS	Horizontal Truss Support	4
SL-70L	Stage/Truss Board Lock	4
SL-70A72M	6' Stage Support Truss	2
Total Weight: 600 lbs.		

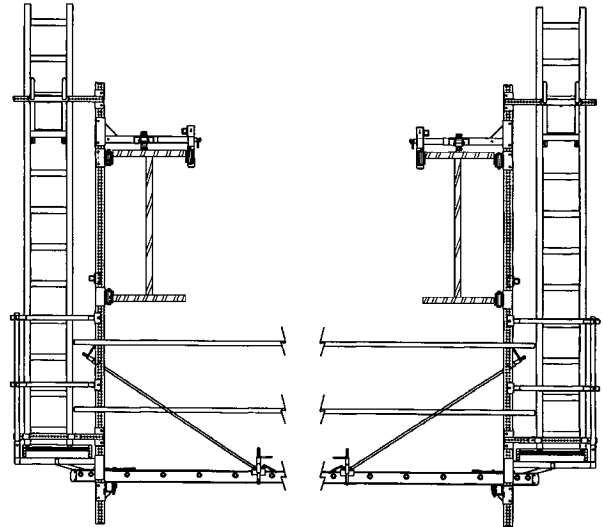

RAILROAD MOBILE CART SCAFFOLD

The Swing-Lo Top Flange Mobile Scaffold is designed to fit types A, AA, and generic railroad bridges. The platform includes access hatch openings at each end, allowing the worker to step onto the girder for advancing the platform. Sliding gates allow for entry and exit. Foot Brakes, Anti-Tip, Adjustable Locks, Guardrails (top and mid) on all sides. The inside lower bumper wheels track the girder.

SL-614PGC TOP FLANGE MOBILE SCAFFOLD		
MODEL	DESCRIPTION	QTY
SL-614PGC	5' x 14' Top Flange Mobile Scaffold	1
Total Weight: 300 lbs.		

SL-614PGC TOP FLANGE MOBILE SCAFFOLD

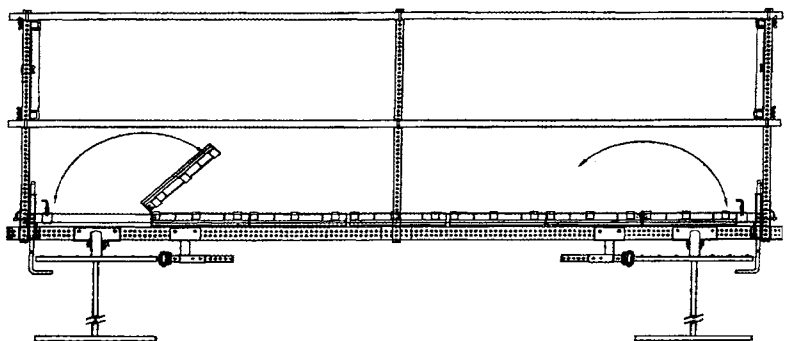

ELEVATED RAIL SCAFFOLD

Designed specifically for railroad bridge inspection and maintenance. The assembly clamps onto the top of the bridge girders. Upper and lower clamp assemblies adjust to top and bottom chords. Standard Vertical Stem lengths are 10 to 12 feet. Additional Stem lengths, Stage Brackets, and Guardrails can be purchased to provide a working platform on both sides and beneath the bridge structure. Guardrails are purchased separately according to job requirements. An alternate configuration can be achieved when Aluminum Stages are used instead of wood decking. In that case, the illustrated Horizontal Truss may be used. Specify width of desired platform.

SL-RRP20 ELEVATED RAIL SCAFFOLD		
MODEL	DESCRIPTION	QTY
SL-90ER	6" - 14" Beam Clamp	4
SL-71A72	6' Galvanized Stems	4
SLP-702A	Needle Beam Hanger	4
SL-B80TB	Toeboard Clamp	4
Total Weight: 138 lbs.		

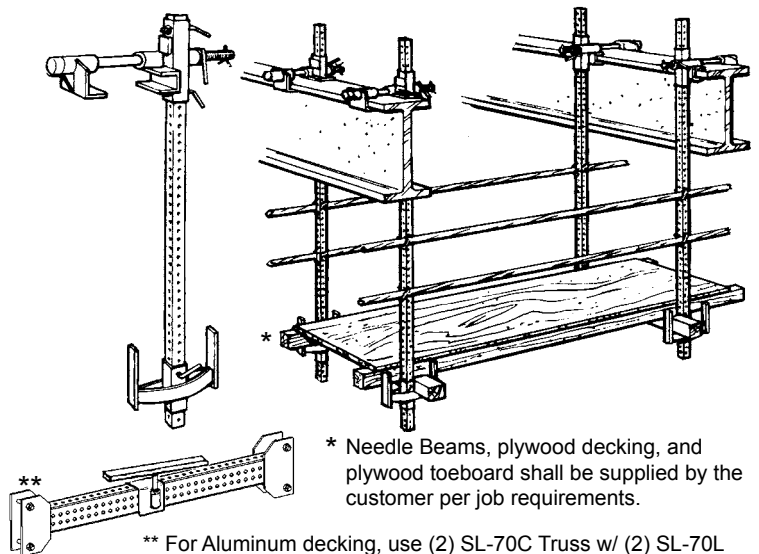

* Needle Beams, plywood decking, and plywood toeboard shall be supplied by the customer per job requirements.

** For Aluminum decking, use (2) SL-70C Truss w/ (2) SL-70L Board Locks instead of SLP-702A Hangers. See page 26, & 6.

RAILROAD SCAFFOLD SYSTEM

Designed specifically for railroad bridge inspection and maintenance. The assembly clamps onto the top of the bridge girders. Upper and lower clamp assemblies adjust to top and bottom chords. Standard Vertical Stem lengths are 10 to 12 feet. Additional Stem lengths, Stage Brackets, and Guardrails can be purchased to provide a working platform on both sides and beneath the bridge structure.

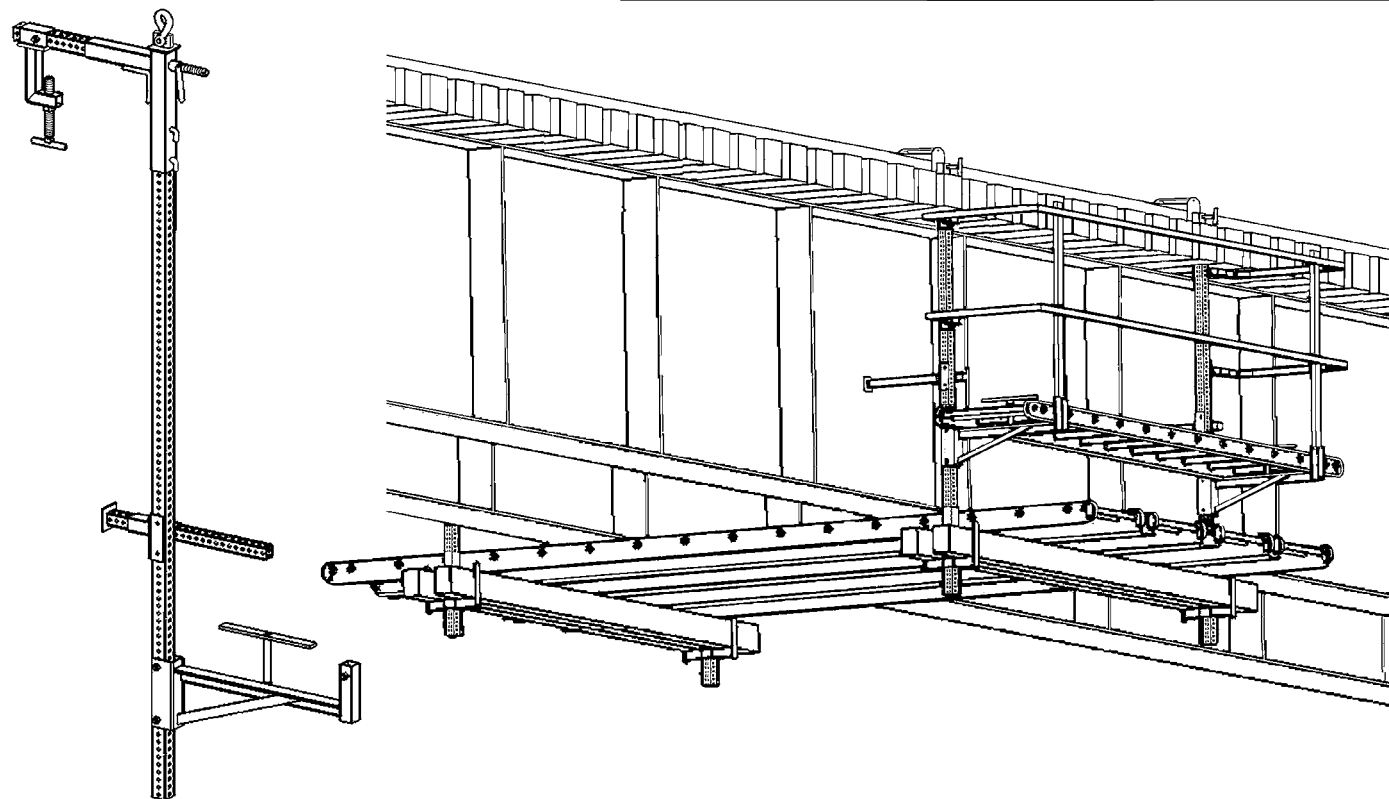
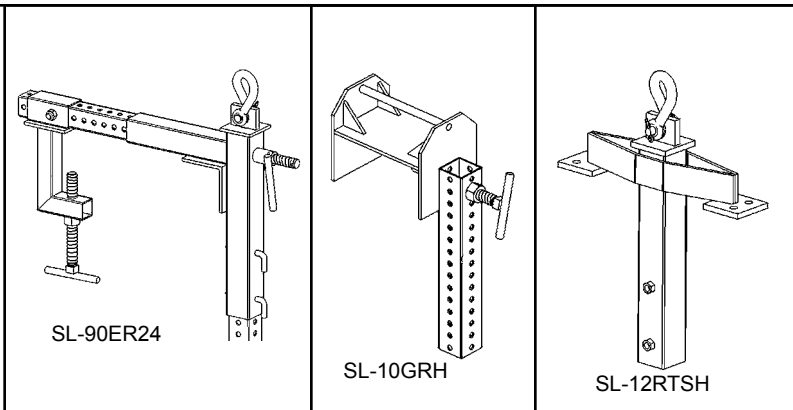

RAILROAD SCAFFOLD SUPPORT SYSTEM - 500 LB. RATED LOAD WITH 4:1 SAFETY FACTOR

TOP SUPPORT	MID SUPPORT	VERTICAL STEM	DECK SUPPORT
<p>Top Girder Clamp: SL-90ER24</p> <ol style="list-style-type: none"> 1. Attach to structural plate girder 2. 12" - 24" Flange width x up to 5.75" thick 3. Lifting Eye for crane setup 	<p>Horizontal Support: SL-1515CA</p> <ol style="list-style-type: none"> 1. Supports Vertical Stem from beam web 2. 12" - 48" braced from the web 	<p>Vertical Stem: SL-71C96, SL-71C144</p> <ol style="list-style-type: none"> 1. 2" x 2" x 8' or 12' galvanized perforated, holes 1" on center. 	<p>Stage Bracket: SL-28SBB</p> <ol style="list-style-type: none"> 1. 28" platform width 2. Guardrail Post Support 3. Stage security tie down
<p>Guardrail Timber Clamp: SL-10GRH</p> <ol style="list-style-type: none"> 1. Attach to Guardrail timber 2. Fits Guardrail timbers 8" wide x 4" high 3. Lifting Eye for crane setup 	<p>Horizontal Support: SL-1515CA</p> <ol style="list-style-type: none"> 1. Supports Vertical Stem from beam web 2. 12" - 48" braced from the web 	<p>Vertical Stem: SL-71C96, SL-71C144</p> <ol style="list-style-type: none"> 1. 2" x 2" x 8' or 12' galvanized perforated, holes 1" on center. 	<p>Stage Bracket: SL-28SBB</p> <ol style="list-style-type: none"> 1. 28" platform width 2. Guardrail Post Support 3. Stage security tie down
<p>Rail Tie Drop-Thru Hanger</p> <ol style="list-style-type: none"> 1. Assembly drops through rail ties 2. Fits minimum opening of 2.75" 3. Lifting Eye for crane setup 	<p>Tie Support Mid Brace: SL-12TSB</p> <ol style="list-style-type: none"> 1. Braces from bottom of tie 2. Adjusts 4" - 8" 	<p>Vertical Stem: SL-71C96, SL-71C144</p> <ol style="list-style-type: none"> 1. 2" x 2" x 8' or 12' galvanized perforated, holes 1" on center. 	<p>Hanger: SL-702RRH</p> <ol style="list-style-type: none"> 1. Support for 6" wide beam 2. Double bolting below base
<p>Concrete Rail Clamp: SL-35BRC1</p> <ol style="list-style-type: none"> 1. Clamp to concrete railing 2. 8" - 14" concrete width, with 8" fixed fascia standoff 3. Lifting Eye for crane setup 	<p>Horizontal Support: SL-1515CA</p> <ol style="list-style-type: none"> 1. Supports Vertical Stem from beam web 2. 12" - 48" braced from the web 	<p>Vertical Stem: SL-71C96, SL-71C144</p> <ol style="list-style-type: none"> 1. 2" x 2" x 8' or 12' galvanized perforated, holes 1" on center. 	<p>Stage Bracket: SL-28SBB</p> <ol style="list-style-type: none"> 1. 28" platform width 2. Guardrail Post Support 3. Stage security tie down

PERIMETER GUARDRAIL POSTS

The SL-G080PP and SL-G080PPC Guardrail Posts are secured by T-Bolt Locks to metal gratings. Guardrails and Toeboards are then attached to provide an entire Guardrail System that keeps hazardous areas in containment and work crews safe.

PERIMETER GUARD RAIL POSTS		
MODEL	DESCRIPTION	WT
SL-G080PPC	Corner Grid Post	18
SL-G080PP	Grid Post	15

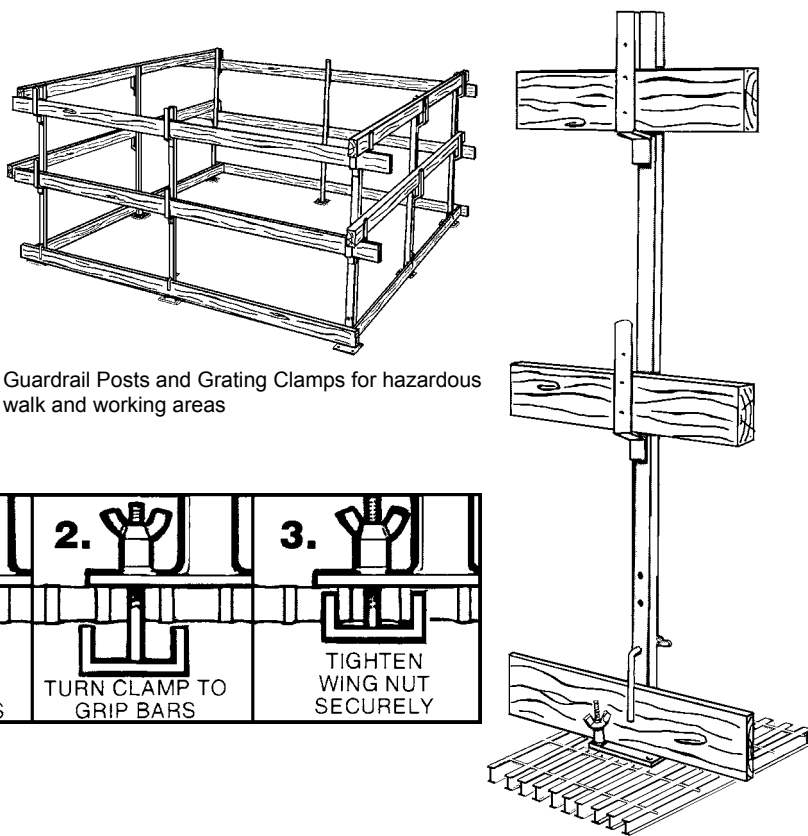

Guardrail Posts and Grating Clamps for hazardous walk and working areas

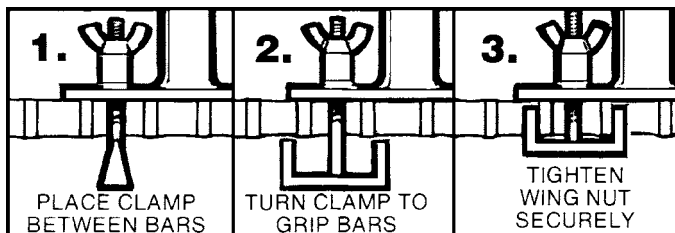
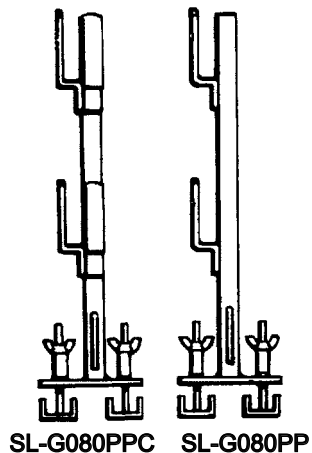

GUARDRAIL SYSTEM FOR FALL PROTECTION

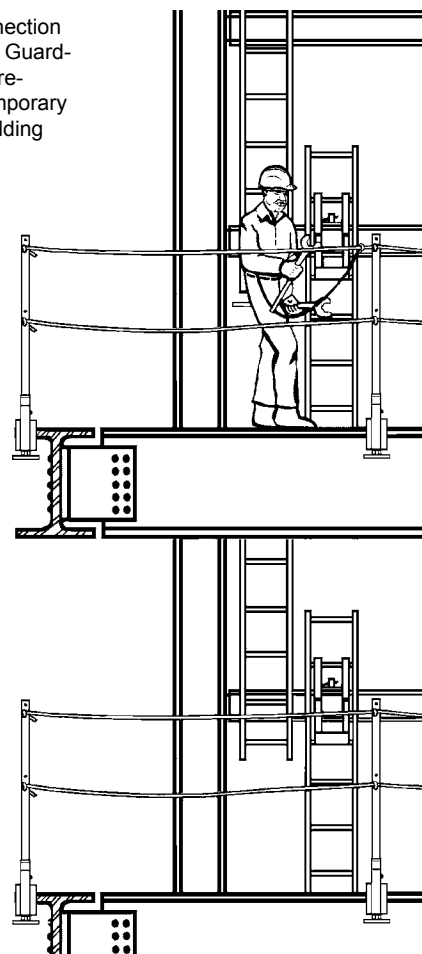
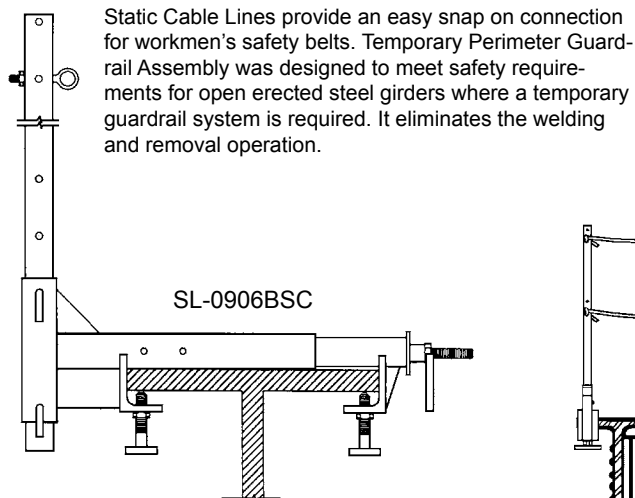
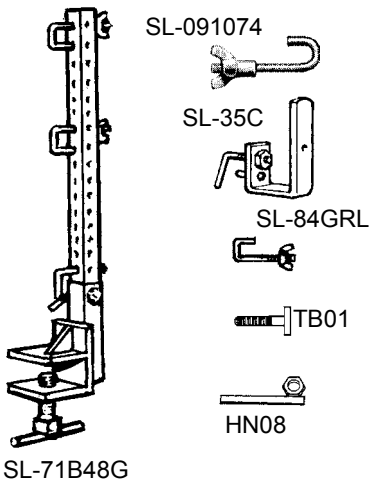

GUARD RAIL POSTS		
MODEL	DESCRIPTION	WT
SL-0906P	Static Line Post w/Eye Bolt	12
SL-71B48M	Pre-galvanized /w Toeboard Clips & Locks	9
GUARD RAIL CLAMPS		
SL-71B48G	Beam Flange Clamp (Open Beam)	12
SL-090BSC	Beam Static Line Clamp w/SL-0906P Post	18
ACCESSORIES		
SL-091074	J-Hook for Wire Rope Rail	1
SL-35C	Safety Rail Bracket (2x4 wood rail)	2
SL-84GRL	Guard Rail Lock for Aluminum Rail	1
TB01	T-Bolt 3/4"	1
HNC8	Handle Lock for 3/4" Threaded Rod	1